

DOPPELSCHLAUFENKUPPLUNG

DOUBLE LOOP COUPLING

DKPS 4848/5658



Schraubnaben

Screw hubs

Technische Daten / technical data		DKPS 4848	DKPS 5658
max. Drehzahl / max. speed	min ⁻¹	3.000	3.000
max. Drehmoment / max. torque	Nm	2	5
max. Wellenversatz / max. offset off shafts			
radial / radial	mm	± 3	± 5
axial / axial	mm	± 4	± 5
angular / angular	Grad	± 12	± 15
Drehfedersteife / torsion spring stiffness	Nm/rad	28	43
Radialfedersteife / radial spring stiffness	N/mm	7	9
Trägheitsmoment / moment of inertia	gcm ²	106	220
max. M der Schrauben / max. clamping torque	Ncm	100	300
Temperaturbereich / temperature range	°C	-30 / +80	-30 / +80
Gewicht ca. / weight appr.	g	85	140
Werkstoff / material	Flansch / flange	Stahl verzinkt / steel galvanized	
Verbindungselement / connecting element		Polyurethan / polyurethane	

M-Anzugsmoment der Gewindestifte/ tightening torque of the set screws
 Gute Beständigkeit gegen Öle, Treibstoffe, Ozon und Witterungseinflüsse
 Passfedernuten ab 6 mm Bohrung möglich
 high resistance to oils, fuels, ozone and weather influences./ Keyways from 6 mm bore possible on request

Ø 95 ≅ Ø 9,52 mm ≅ Ø 3/8"

DKPS 4848

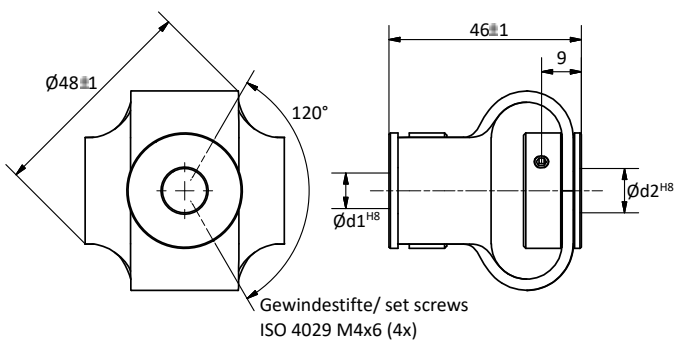

Bohrungskombinationen / bore combinations DKPS 4848						
d1 / d2	6	8	95	10	12	14
6	X	X	X	X	X	X
8		X	X	X	X	X
95			X	X	X	X
10				X	X	X
12					X	X
14						X
Bestellbeispiel / Example DKPS 4848 06/95						

DKPS 5658

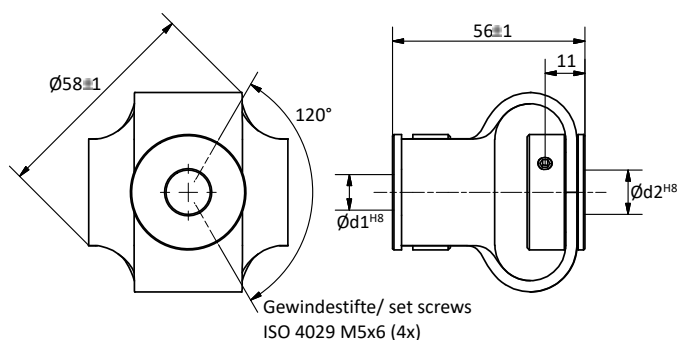

Bohrungskombinationen / bore combinations DKPS 5658						
d1 / d2	10	12	14	16	18	19
10	X	X	X	X	X	X
12		X	X	X	X	X
14			X	X	X	X
16				X	X	X
18					X	X
19						X
Bestellbeispiel / Example DKPS 5658 10/14						